



OBRAZAC 1

elektronski potpis projektanta	elektronski potpis revidenta
--------------------------------	------------------------------

INVESTITOR: Jovan Abazović, Bar, Crna Gora

OBJEKAT: Javno porodično kupalište

LOKACIJA: Kupalište u Čanju br 2A, kp 1281/1 KO Mišići, Opština Bar predviđeno - Programom privremenih objekata u zoni morskog dobra u opštini Bar za period 2019.-2023.godine

VRSTA TEHNIČKE DOKUMENTACIJE: IDEJNO RJEŠENJE

PROJEKTANT A12 project d.o.o. Podgorica, Moskovska 111/50, 81000 Podgorica

ODGOVORNO LICE Slobodan Petrović spec.sci.arh. br.licence UPI 105/2175-46/2

GLAVNI INŽENJER Slobodan Petrović spec.sci.arh. br.licence UPI 105/2175-46/2



elektronski potpis projektanta	elektronski potpis revidenta
--------------------------------	------------------------------

INVESTITOR: Jovan Abazović, Bar, Crna Gora

OBJEKAT: Javno porodično kupalište

LOKACIJA: Kupalište u Čanju br 2A, kp 1281/1 KO Mišići, Opština Bar predviđeno - Programom privremenih objekata u zoni morskog dobra u opštini Bar za period 2019.-2023.godine

DIO TEHNIČKE DOKUMENTACIJE: ARHITEKTURA

PROJEKTANT: A12 project d.o.o. Podgorica, Moskovska 111/50, 81000 Podgorica

ODGOVORNO LICE: Slobodan Petrović, spec.sci.arh.
br.licence UPI 105/2175-46/2

GLAVNI INŽENJER: Slobodan Petrović, spec.sci.arh.
br.licence UPI 105/2175-46/2

SARADNICI NA PROJEKTU: _____

SADRŽAJ DIJELA TEHNIČKE DOKUMENTACIJE_ARHITEKTURA

1. TEKSTUALNA DOKUMENTACIJA

1.1 Tehnički opis

2. GRAFIČKA DOKUMENTACIJA

2.1	Situacija	1:750
2.2	Situacija sa dispozicijom opreme	1:750
2.3	Spasilački punkt-osnova, presjeci, izgledi	1:50
2.4	Informativne table, zastave, plažni mobilijar	1:50

3. TRODIMENZIONALNI PRIKAZI



A12 project d.o.o.
Moskovska 111/50
Podgorica 81000, Montenegro
Mob: +382 69 746 284
Email: info@a12project.com
Web: www.a12project.com

ARCHITECTURE – DESIGN – ENGINEERING – CONSULTING - BUILDING

1. TEKSTUALNA DOKUMENTACIJA



A12 project d.o.o.
Moskovska 111/50
Podgorica 81000, Montenegro
Mob: +382 69 746 284
Email: info@a12project.com
Web: www.a12project.com

ARCHITECTURE – DESIGN – ENGINEERING – CONSULTING - BUILDING

1.1.

Tehnički opis

TEHNIČKI OPIS

Za izradu idejnog rješenja javnog-porodičnog kupališta

Investitor: Jovan Abazović, Bar, Crna Gora

Lokacija: Kupalište u Čanju br 2A, kp 1281/1KO Mišići, Opština Bar predviđeno Programom privremenih objekata u zoni morskog dobra u opštini Bar za period 2019.-2023. godine

Idejno rješenje javnog-porodično kupalište rađeno je na osnovu urbanističko-tehničkih uslova broj: 0206-1402/5 za kupalište u Baru br. 2A, kp 1281/1 KO Mišići, Opština Bar predviđeno - Programom privremenih objekata u zoni morskog dobra u Opštini BAR za period 2019. - 2023. godine.

Urbanistički pokazatelji:

Namjena: Javno-porodično kupalište

Broj kupališta: 2A

Broj katastarske parcele: 1281/1KO Mišići, Opština Bar

Dužina kupališta: 50m

Maksimalna površina plažnog prostora: 1260 m²

Maksimalna površina ½ kupališta oslobođenog od p. mobilijara: 630 m²

Maksimalni broj suncobrana: 49

Maksimalni broj ležaljki: 98

Pregled planiranih objekata (mobilijar, sanitarni objekti, kabine za presvlačenje, korpe za otpatke, protivpožarni aparat, tuševi, info table,...) na kupalištu 2A:

Ukupan broj suncobrana: 49

Ukupan broj ležaljki: 98

Ukupan broj mobilnih sanitarnih objekata – toaleta: 1

Ukupan broj kabina za presvlačenje: 2

Ukupan broj tuševa: 32

Ukupan broj protivpožarnih aparata: 1

Ukupan broj korpi za otpatke: 5

Ukupan broj tabli sa informacijama o plažnom redu: 1

Ukupan broj table sa informacijama o kupalištu: 1

Ukupan broj spasilačkih punktova: 1

Ukupan broj informativnih zastavica: 1

Kupalište – namjena, sadržaji, izgled, materijali:

Kupalište 2A u Čanju ima dužinu 50 m, maksimalnu površinu plažnog prostora 1260 m² i maksimalnu površinu ½ kupališta oslobođenog od plažnog mobilijara 630 m². Kupalištu je moguće pristupiti sa šetališta do dijela gdje su ležaljke i suncobrani i dijela koji je oslobođen plažnog mobilijara. Na kupalištu je pozicioniran punkt za spasioca sa informativnom zastavicom. Obezbijeđen je dovoljni broj kanti za otpatke. Na kupalište su pozicionirani i tuševi, kabine za presvlačenje i mobilni toalet. Na ulazu kupalište je planirano postavljanje table sa informacijama o plažnom redu i o kupalištu. Između prvog reda ležaljki i suncobrana i vode ostavljen je čisti prostor od minimum 3 m koji je tražen po UT uslovima. Tokom planiranja i pozicija objekata na kupalištu vodilo se računa da se korisnicima kupališta obezbijedi ne smetan prolaz do mora. Površina plažnog prostora koji je planiran za pozicioniranje plažnog mobilijara – ležaljki i suncobrana je 630 m².

Primjer planiranih objekata (mobilijar, sanitarni objekti, kabine za presvlačenje, korpe za otpatke, protivpožarni aparat, tuševi, info table,...) na kupalištu 2A:



Primjer korpi za otpatke na kupalištu 2A

MIRÒ

CLASSIC BEACH UMBRELLA WITH VALANCE

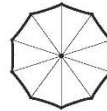

* For the base see accessories page



Assisted and safety umbrella closing system mod. *Diamante*.

Allows closing the beach umbrella simply by lowering without having to adjust springs or press buttons. Collar and crown in special technopolymer elastomerised and stabilised.



10 ribs diameter 5 in hot dip galvanised steel with layer of high quality epoxy powder paint made from harmonic steel wire. A thin brass sheet joins the short rib to the long rib. Joints are protected by an oval piece of *Sky fabric*.



Upper pole has female coupling and *Baionetta* locking system.



Stainless steel knob.



Fabric fixed using a screw system making it more long-lasting.

Diameter (cm.)	Ribs (cm/h°)	Weight (Kg.)	Box
Ø 180	90 / 10	4,30	5 pz. / 28 x 28 x 150 cm. m ³ 0,12 Kg. 22,50
Ø 200	100 / 10	4,70	5 pz. / 28 x 28 x 150 cm. m ³ 0,12 Kg. 24,10
Ø 220	110 / 10	5,10	5 pz. / 28 x 28 x 150 cm. m ³ 0,13 Kg. 25,70
Ø 240	120 / 10	5,50	5 pz. / 28 x 28 x 170 cm. m ³ 0,13 Kg. 27,30
Ø 260	130 / 10	5,90	5 pz. / 28 x 28 x 170 cm. m ³ 0,13 Kg. 28,90



World exclusivity of **TEMPOTEST PARÀ** mare fabrics, 100% MADE IN ITALY, made especially in h. 115 to allow the use of the selvedge on the edges, helping to increase its life. 100% acrylic, mass dyed, colour fast with 6-year guarantee, exceptionally long-lasting also thanks to its weight of 290 gr/sqm.

OPTIONAL FOR BEACH UMBRELLA



Joint for beach umbrella



System mod. *Scirocco*
To fix pole with Allen key



Windproof Vent

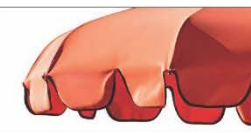

Valance mod. *Charlestone*



Model suncobrana planiranih na kupalištu 2A

LETTINO

SUNBEDS 500 - 501

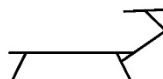

L.182 / P.73 / H.40 cm

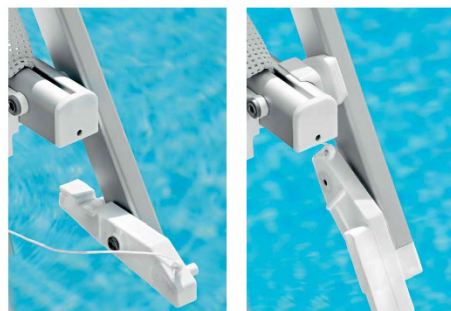

Sunbed Mod. 500 without spacer: Sunbed Mod. 501 with spacer



The frame is made in primary aluminium casting, using top quality tempered virgin alloys. The parts are anodised 20 micron, with *Qualanod* certification from the Italian Institute *Qualital*.

Fabrics

Plasticised fabric 100% made in Italy, made using a continuous polyester fibre thread covered in PVC. Strong fibre, guaranteed in time, highly wear-resistant. All fibres have *Oeko Tex® - Standard 100* certification for the absence of harmful substances and *Catas* for tensile strength and wear resistance. Can be customised with silk-screened prints or with heat-welded wording in standard characters.



All the elements are assembled with the use of *Aisi 304* stainless steel nuts and bolts, and *Aisi 316* washers. Between the steel parts there are protective nylon disks.



The holes in the structure for the application of the fabric and the insertion of the plugs that fix it, are achieved by conical punching (flaring). This allows the insertion of all the nylon accessories (plugs, nails etc.), without scraps of material (no curls), and consequently all fixing is perfect and immovable. All the plastic parts used in the assembly of the frame have been moulded internally in our plant using top quality Nylon. The sunbed has a system that blocks the legs, once they are open, in order to reduce the risk of injury to the hands caused by accidental closure. The Nylon balancers regulate the backrest in 3 positions.

	Unit	Dim. (cm.)	Vol. (m ³)	Weight (Kg.)
Box	2	21 x 77 x 155	0,25	21,00
Pallet	20	200 x 80 x 155	2,40	240,00

OPTIONAL SUNBED



Cushion



Wheels

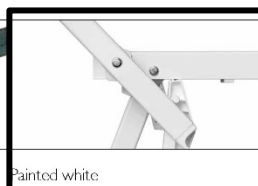

Painted white



Anodised silver (standard)



Painted graphite



Anodised bronze Smeca

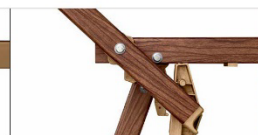

Wood effect



Sunbed without sunshade

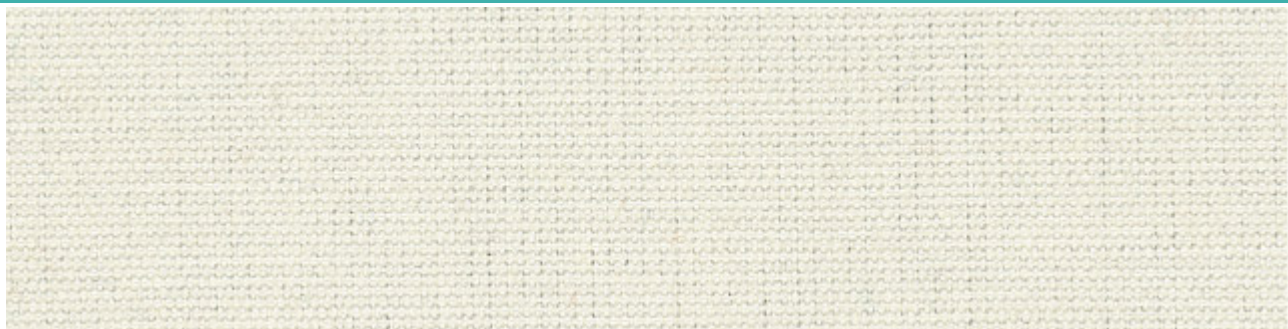

Boja i tekstura materijala suncobrana planiranih na kupalištu 2A

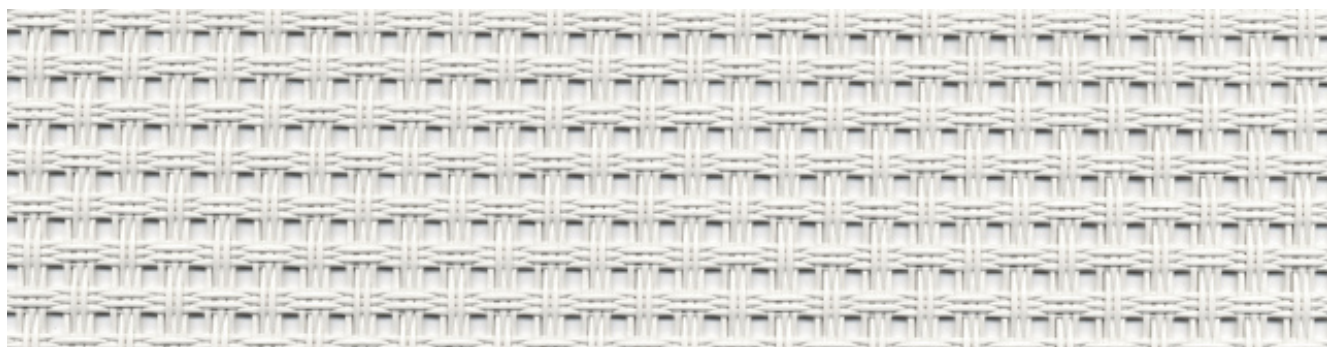

Boja i tekstura materijala ležaljki planiranih na kupalištu 2A



Primjer spasilačkog punkta na kupalištu 2A

OBAVEZNI SADRŽAJ INFORMATIVNE TABLE JAVNO UREĐENO KUPALIŠTE

Primjer:



skica br. 2

Lučka kapetanija Bar +382 30 312 733
 Lučka kapetanija Kotor +382 32 304 312

Primjer informativne table sa informacijama o kupalištu

**OBAVEZNI SADRŽAJ INFORMATIVNE TABLE
PLAŽNOG REDA**

70 cm

**PLAŽNI RED
BEACH CODE OF
CONDUCT**



ZABRANJENO BACANJE OTPADAKA PO PLAŽI
LITTERING IS FORBIDDEN



ZABRANJENO KAMPOVANJE NA PLAŽI
CAMPING ON THE BEACH IS NOT ALLOWED



ZABRANJENO PALJENJE VATRE NA PLAŽI
OPEN FIRE ON THE BEACH IS NOT ALLOWED



ZABRANJENO UVOĐENJE KUĆNIH LJUBIMACA
PETS ON THE BEACH ARE NOT ALLOWED



ZABRANJENO KORIŠĆENJE ŠAMPONA
SHAMPOO USE IS NOT ALLOWED IN THE
BEACH SHOWERS



ZABRANJENO ULAŽENJE VOZILIMA NA PLAŽU
VEHICLE DRIVING ON THE BEACH IS FORBIDDEN



ZABRANJENO NAPLAĆIVANJE ULAZA
CHARGING OF ENTRANCE FEES IS NOT ALLOWED



ZABRANJENO USLOVLJAVANJE OBAVEZNIM KORIŠĆENJEM
PLAŽNOG MOBILIJARA
RENTING SUNUMBRELLAS AND SUNBEDS IS NOT A PRECONDITION
FOR USING THE BEACH



ZABRANJENO KRETANJE PLOVILA U VODENOM PROSTORU
OGREĐENOG KUPALIŠTA
USE OF MOTOR WATER-CRAFTS AND JET SKIS IN BORDERED
SWIMMING AREA IS FORBIDDEN

130 cm

skica br. 3

Primjer informativne table sa informacijama o plažnom redu



Primjer informativne table sa informacijama o bezbjednosti na plaži



A12 project d.o.o.
Moskovska 111/50
Podgorica 81000, Montenegro
Mob: +382 69 746 284
Email: info@a12project.com
Web: www.a12project.com

ARCHITECTURE – DESIGN – ENGINEERING – CONSULTING - BUILDING

Podgorica, Jul 2019.

Odgovorni inženjer:
Slobodan Petrovic spec.sci.arch.

A handwritten signature in blue ink, written over a horizontal line. The signature is stylized and appears to read 'Slobodan Petrovic'.



A12 project d.o.o.
Moskovska 111/50
Podgorica 81000, Montenegro
Mob: +382 69 746 284
Email: info@a12project.com
Web: www.a12project.com

ARCHITECTURE – DESIGN – ENGINEERING – CONSULTING - BUILDING

2. GRAFIČKA DOKUMENTACIJA

Idejno rješenje javnog porodičnog kupališta - Jul 2019

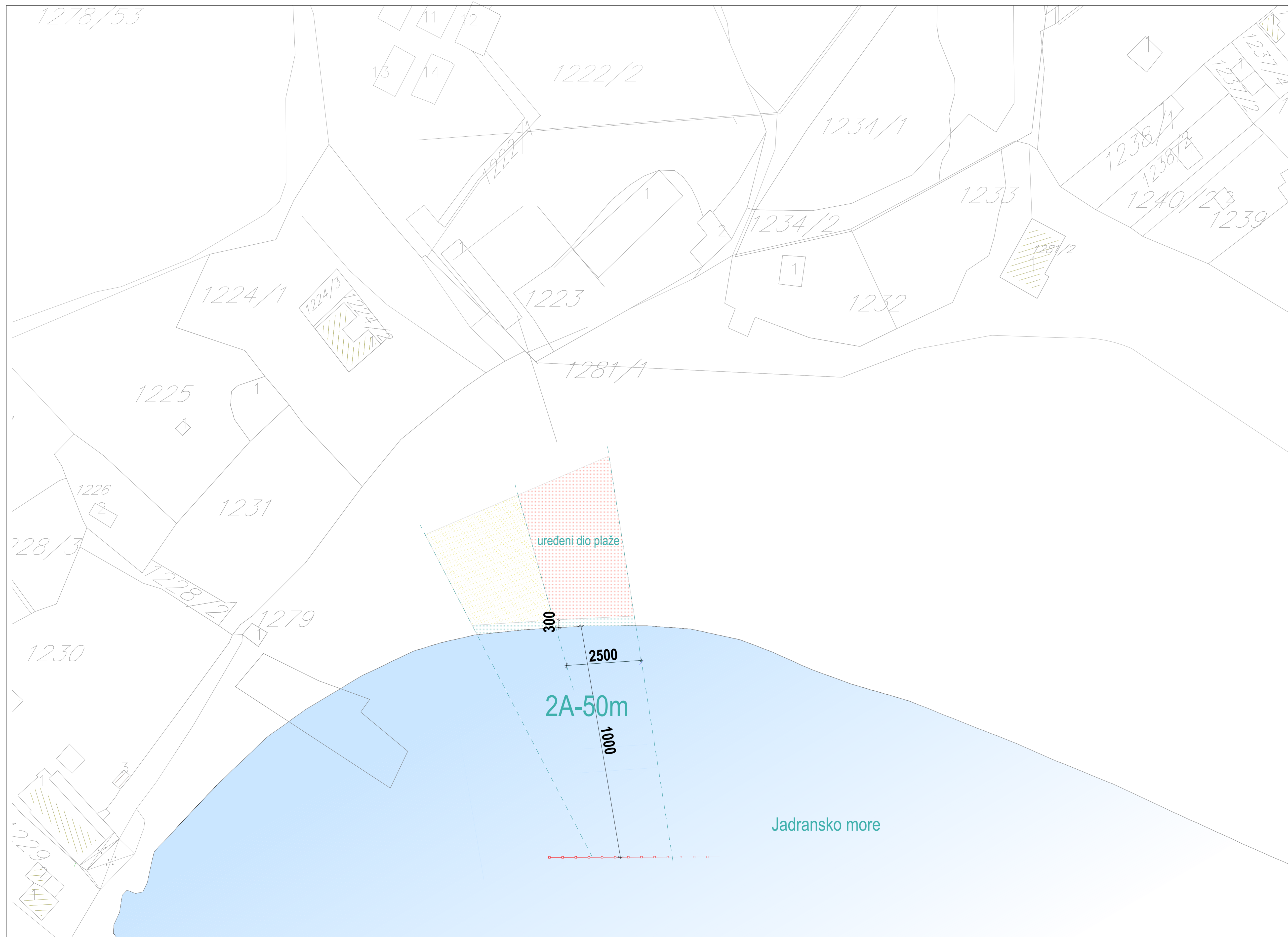

LEGENDA

	lokacija 2A - dužina 50m
	uređeni dio plaže
	prostor oslobođen od plažnog mobilijara
	zona uz more

	Adresa: Moskovska 111/50 81000 Podgorica, Crna Gora Mob: +38269746294 Email: info@a12project.com Web: www.a12project.com	Projektant: A12 project d.o.o. Podgorica, Crna Gora	Investitor: Jovan Abazović Bar, Crna Gora
	Objekat: Organizacija javnog-porodičnog kupališta	Lokacija: Kupalište u Čanju br 2A, kp 1281/1 KO Mišići, Opština Bar predviđeno - Programom privremenih objekata u zoni morskog dobra u opštini Bar za period 2019.-2023.godine	
Glavni inženjer: Slobodan Petrović, spec.sci.arh. UPI 101/2175-46/2	Vrsta tehničke dokumentacije: IDEJNO RJEŠENJE	Oznaka projekta:	
Odgovorni inženjer: Slobodan Petrović, spec.sci.arh. UPI 101/2175-46/2	Dio tehničke dokumentacije: ARHITEKTURA	Razmjera: 1:750	
Saradnik/ci:	Prilog: Šira situacija	Br. priloga: 1	Br. strane:
Datum izrade i M.P.	02.07.2019	Datum revizije i M.P.	

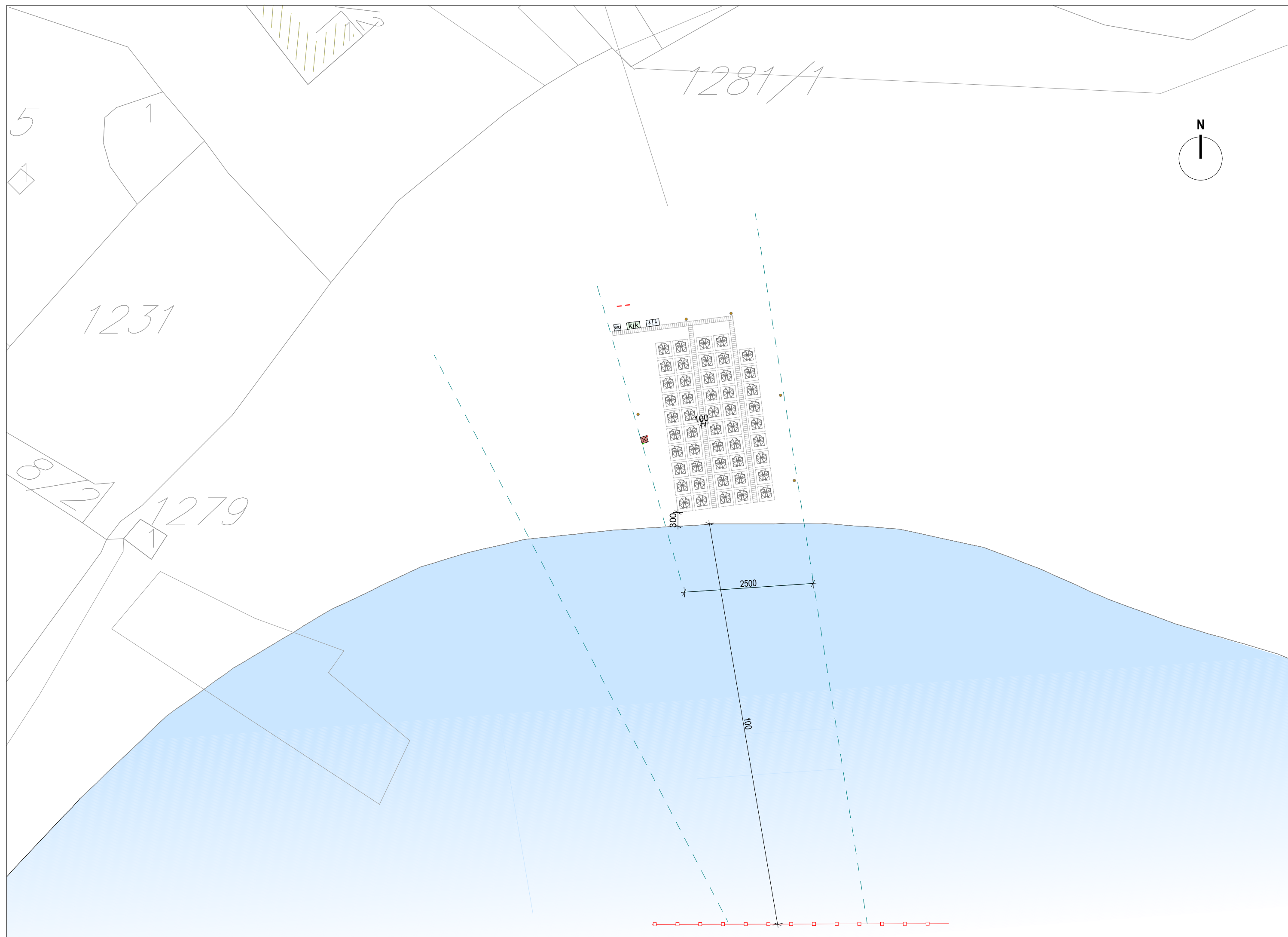

LEGENDA

	plažni mobilijar, suncobran i ležaljke
	tabla sa informacijama o kupalištu
	tabla sa informacijama o plažnom redu
	mobilni sanitarni čvor
	mobilna korpa za otpatke
	tuševi
	kabine za presvlačenje
	protivpožarni aparat
	spasilački punkt
	informativna zastavica
	bove
	granica zone kupališta
	pristup do mora, širine 1m



Adresa: Moskovska 111/50 81000
Podgorica, Crna Gora
Mob: +38269746294
Email: info@a12project.com
Web: www.a12project.com

Projektant:
A12 project d.o.o.
Podgorica, Crna Gora

Investitor:

Jovan Abazović
Bar, Crna Gora

Objekat:
Organizacija javnog-porodičnog kupališta

Lokacija:
Kupalište u Čanju br 2A, kp 1281/1 KO Mšići, Opština Bar predviđeno - Programom privremenih objekata u zoni morskog dobra u opštini Bar za period 2019.-2023.godine

Glavni inženjer:
Slobodan Petrović, spec.sci.arh. UPI 101/2175-46/2

Vrsta tehničke dokumentacije:
IDEJNO RJEŠENJE

Oznaka projekta:

Odgovorni inženjer:
Slobodan Petrović, spec.sci.arh. UPI 101/2175-46/2

Dio tehničke dokumentacije:
ARHITEKTURA

Razmjera:
1:750

Saradnik/ci:

Prilog:
Situacija sa dispozicijom opreme

Br. priloga:
2

Datum izrade i M.P.
02.07.2019

Datum revizije i M.P.

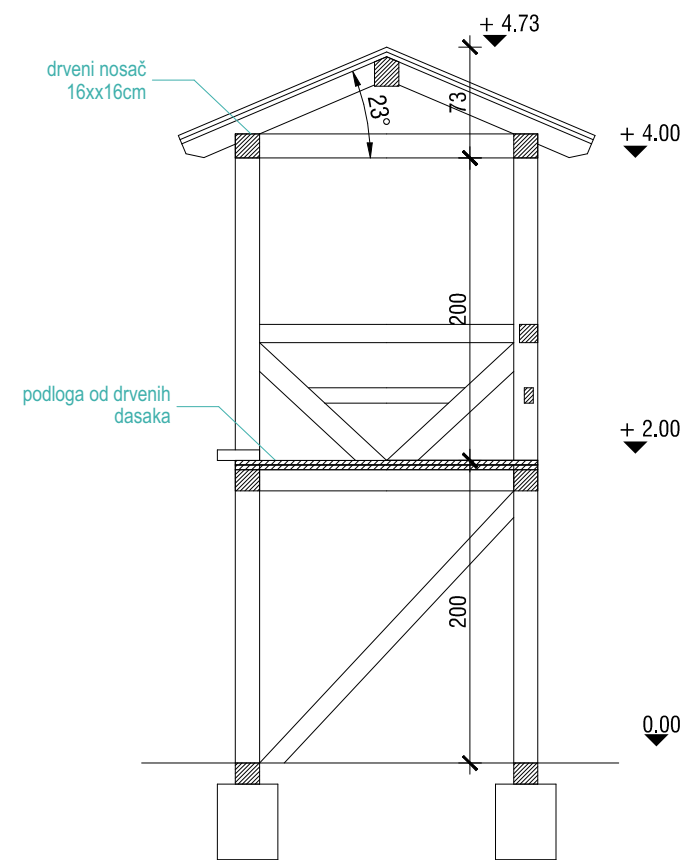

PRESJEK

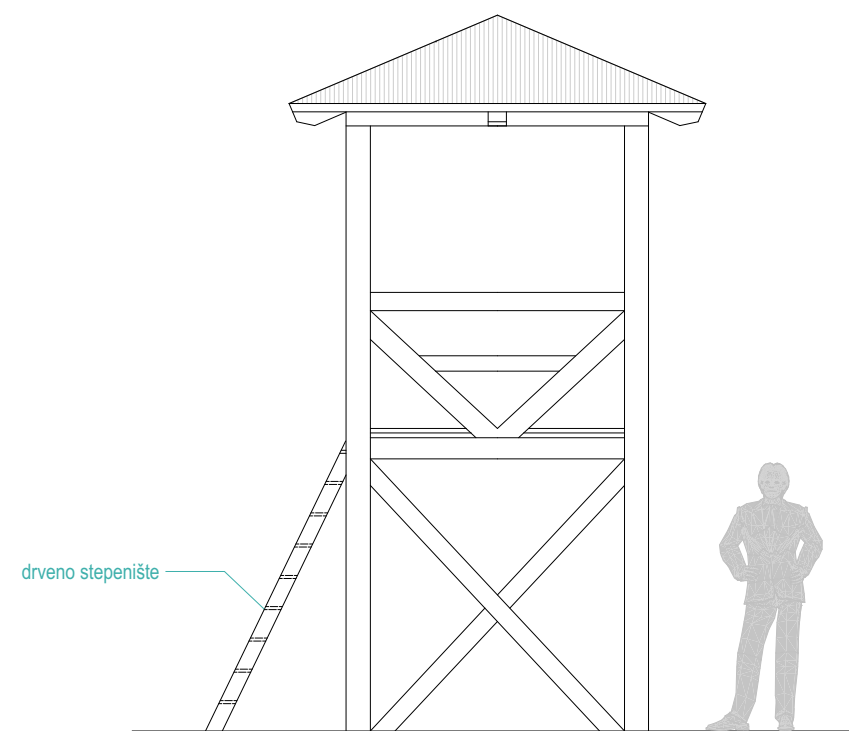

BOČNI IZGLED

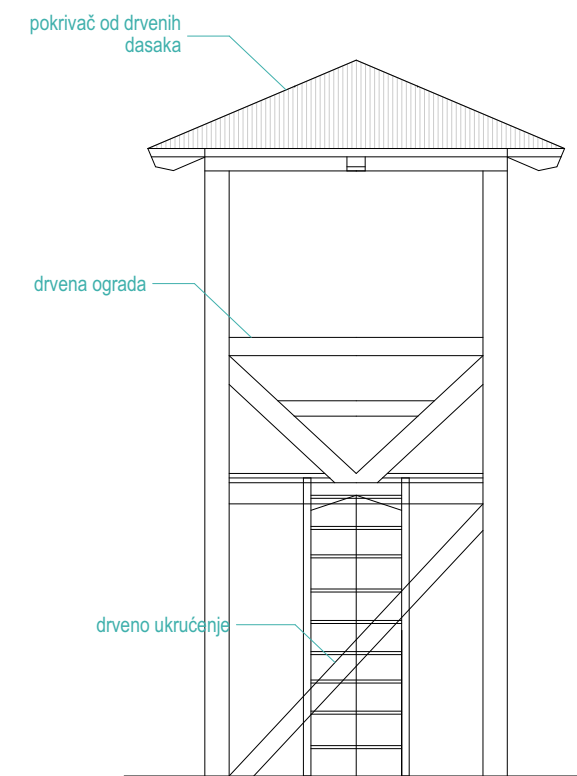

PREDNJI IZGLED

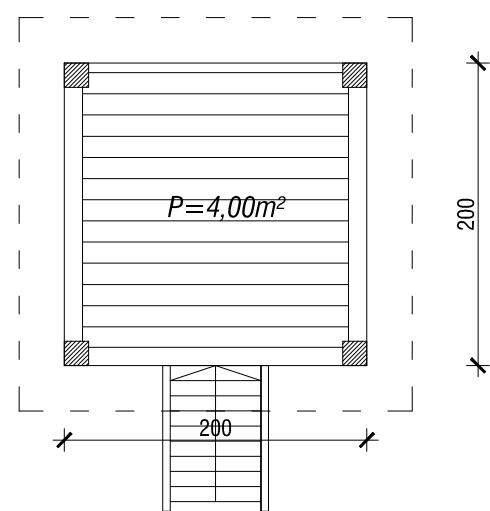

OSNOVA

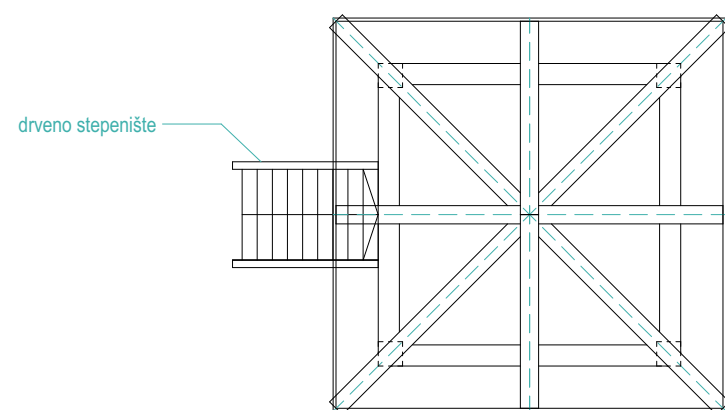

OSNOVA KROVNE KONSTRUKCIJE

 Adresa: Moskovska 111/50 81000 Podgorica, Crna Gora Mob: +38269746294 Email: info@a12project.com Web: www.a12project.com		Projektant: A12 project d.o.o. Podgorica, Crna Gora	Investitor: Jovan Abazović Bar, Crna Gora
Objekat: Organizacija javnog-porodičnog kupališta	Lokacija: Kupalište u Čanju br 2A, kp 1281/1 KO Mšići, Opština Bar predviđeno - Programom privremenih objekata u zoni morskog dobra u opštini Bar za period 2019.-2023.godine		
Glavni inženjer: Slobodan Petrović, spec.sci.arh. UPI 101/2175-46/2	Vrsta tehničke dokumentacije: IDEJNO RJEŠENJE	Oznaka projekta:	
Odgovorni inženjer: Slobodan Petrović, spec.sci.arh. UPI 101/2175-46/2	Dio tehničke dokumentacije: ARHITEKTURA	Razmjera: 1:50	
Saradnik/ci:	Prilog: Spasilački punkt-osnova, presjeci, izgledi	Br. priloga: 3	Br. strane:
Datum izrade i M.P. <p style="text-align: right;">02.07.2019</p>	Datum revizije i M.P.		

INFORMATIVNE TABLE



TABLA SA INFORMACIJAMA O KUPALIŠTU dim 100X100cm



TABLA SA INFORMACIJAMA O PLAŽNOM REDU dim 100X100cm

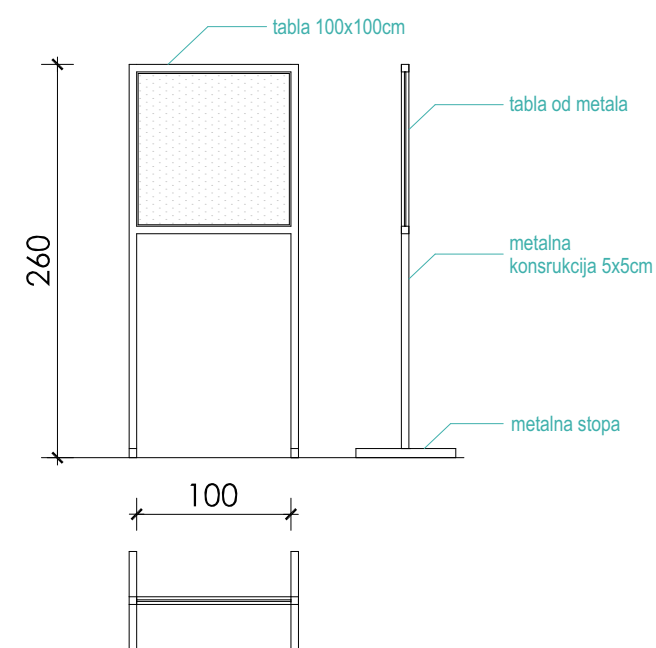

TABLA SA INFORMACIJAMA O BEZBJEDNOSTI KUPAČA dim 100X150cm
POSTAVLJA SE NA SPASILAČKOJ KULI

PLAŽNI MOBILIJAR - LEŽALJKA I SUNCOBAN

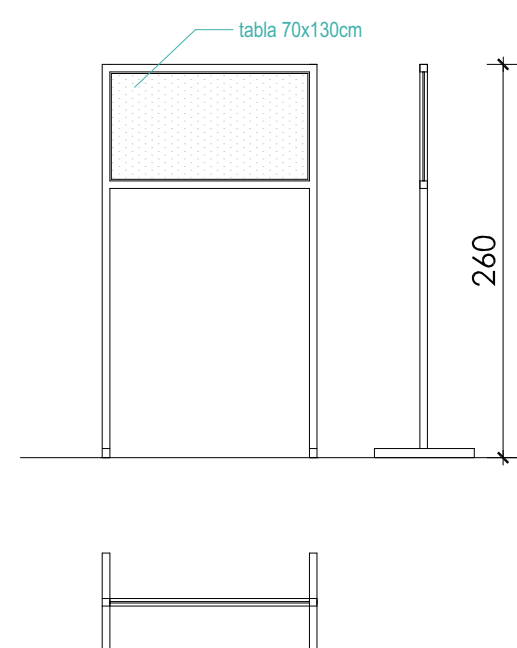

INFORMATIVNE ZASTAVE

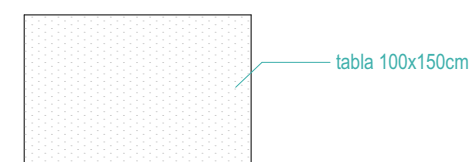
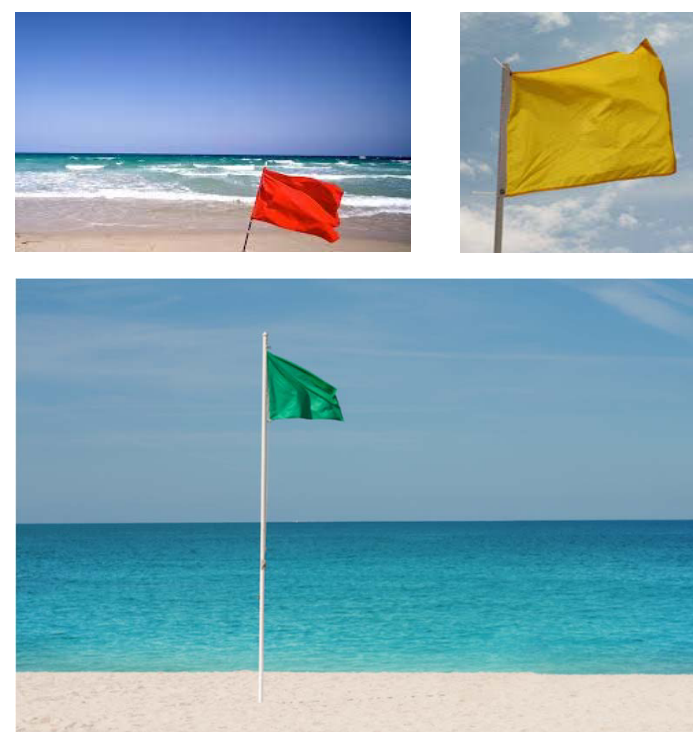

SPASILAČKI PUNKT



 Adresa: Moskovska 111/50 81000 Podgorica, Crna Gora Mob: +38269746294 Email: info@a12project.com Web: www.a12project.com	Projektant: A12 project d.o.o. Podgorica, Crna Gora	Investitor: Jovan Abazović Bar, Crna Gora
	Objekat: Organizacija javnog-porodičnog kupališta	Lokacija: Kupalište u Čanju br 2A, kp 1281/1 KO Mšići, Opština Bar predviđeno - Programom privremenih objekata u zoni morskog dobra u opštini Bar za period 2019.-2023.godine
Glavni inženjer: Slobodan Petrović, spec.sci.arh. UPI 101/2175-46/2	Vrsta tehničke dokumentacije: IDEJNO RJEŠENJE	Oznaka projekta:
Odgovorni inženjer: Slobodan Petrović, spec.sci.arh. UPI 101/2175-46/2	Dio tehničke dokumentacije: ARHITEKTURA	Razmjera: 1:50
Saradnik/ci:	Prilog: Informativne table, zastave i plažni mobilijar	Br. priloga: 4
Datum izrade i M.P. 02.07.2019	Datum revizije i M.P.	

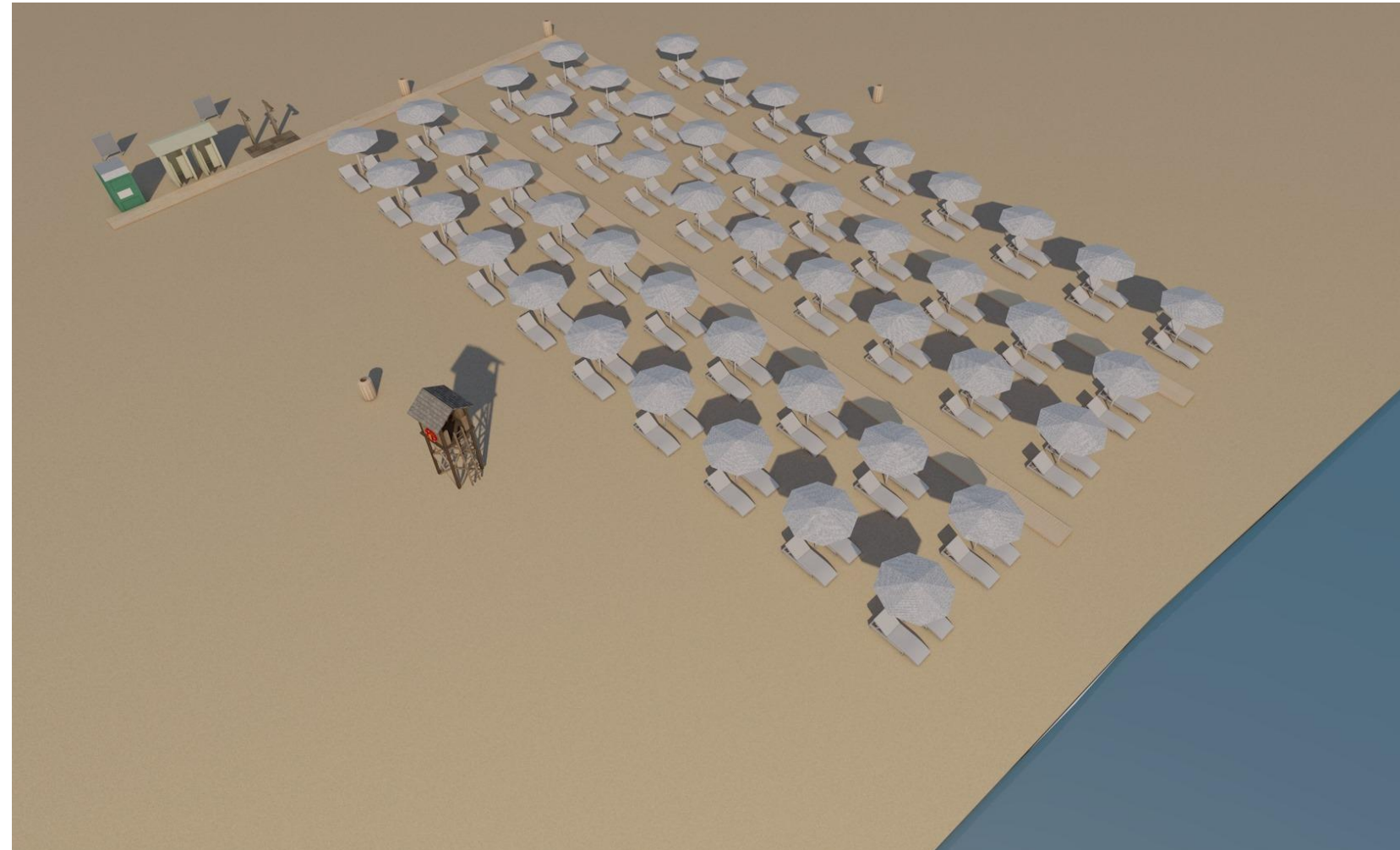
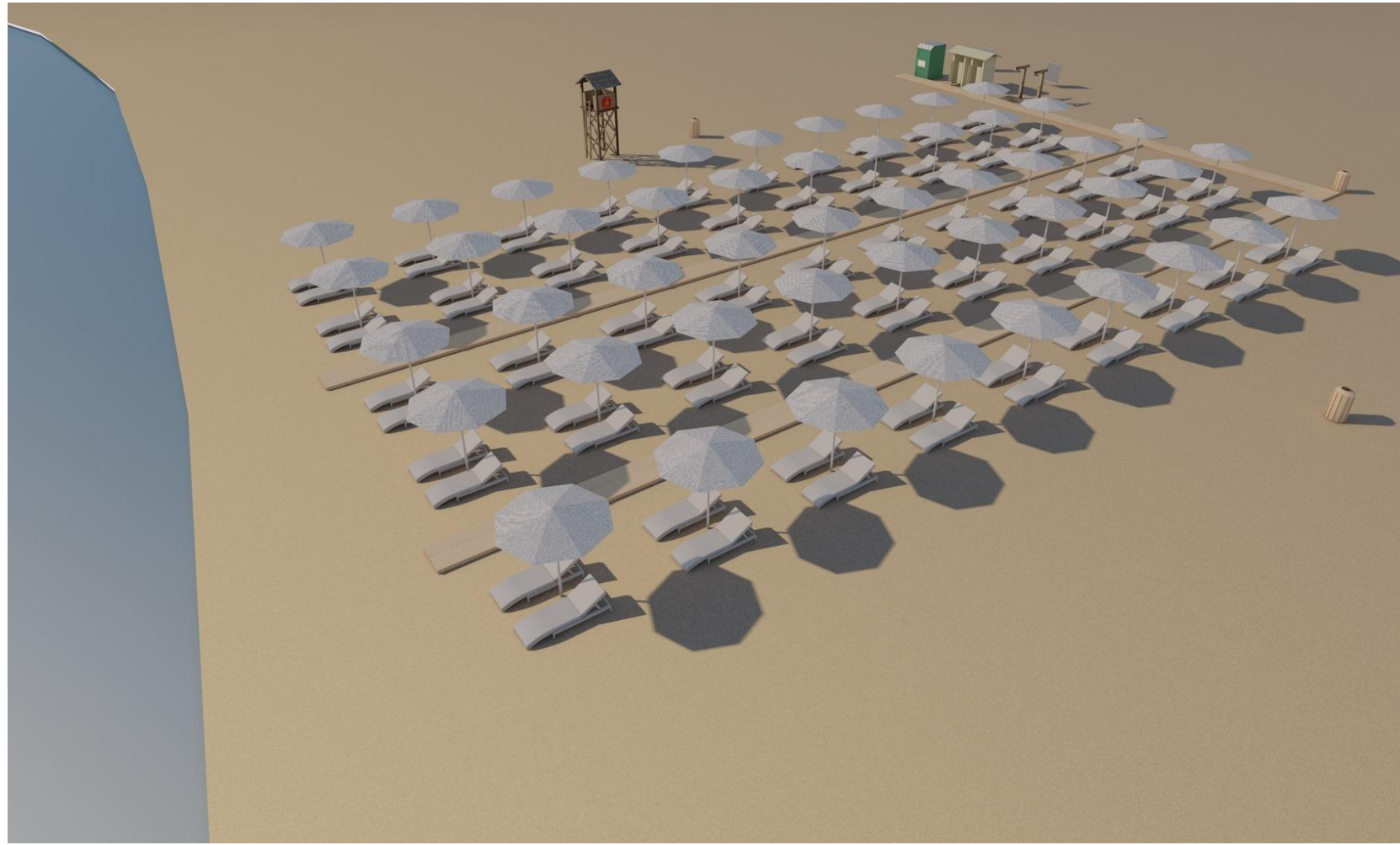

 Adresa: Moskovska 111/50 81000 Podgorica, Crna Gora Mob: +38269746294 Email: info@a12project.com Web: www.a12project.com		Projektant: A12 project d.o.o. Podgorica, Crna Gora	Investitor: Jovan Abazović Bar, Crna Gora
Objekat: Organizacija javnog-porodičnog kupališta	Lokacija: Kupalište u Čanju br 2A, kp 1281/1 KO Mšići, Opština Bar predviđeno - Programom privremenih objekata u zoni morskog dobra u opštini Bar za period 2019.-2023.godine		
Glavni inženjer: Slobodan Petrović, spec.sci.arh. UPI 101/2175-46/2	Vrsta tehničke dokumentacije: IDEJNO RJEŠENJE	Oznaka projekta:	
Odgovorni inženjer: Slobodan Petrović, spec.sci.arh. UPI 101/2175-46/2	Dio tehničke dokumentacije: ARHITEKTURA	Razmjera:	
Saradnik/ci:	Prilog: 3d prikaz kupališta	Br. priloga: 5	Br. strane:
Datum izrade i M.P <p style="text-align: right;">02.07.2019</p>	Datum revizije i M.P		